

- DE Gebrauchsanleitung
- FR Mode d'emploi
- NL Gebruikershandleiding
- GB User guide
- ES Guía del usuario
- IT Manuale di istruzioni
- SE Bruksanvisning
- CZ Uživatelská příručka
- DK Brugervejledning
- FI Käyttöohjeet
- GR Οδηγός χρήστη
- NO Brukerveiledning
- PL Instrukcja obsługi

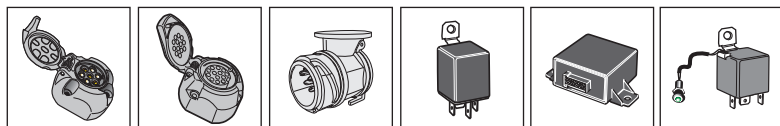

### SPARE PARTS

[www.ecs-electronics.com](http://www.ecs-electronics.com)

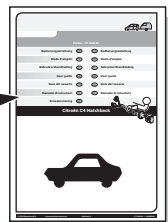

Partnr.: MB-070-B1



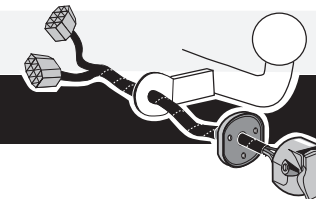

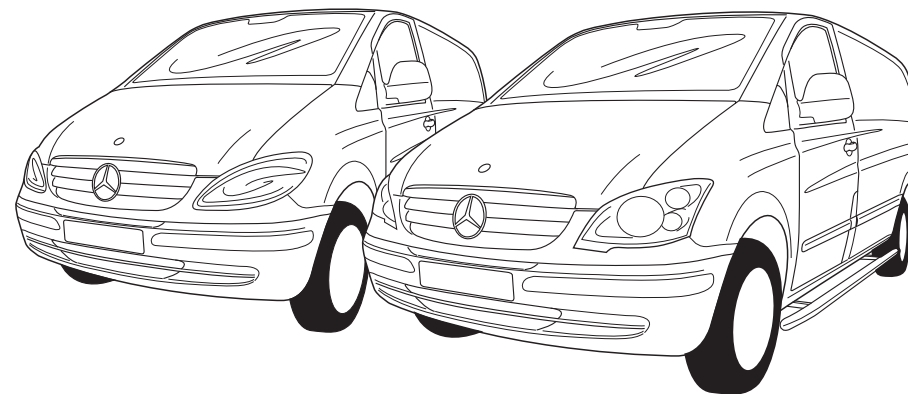

Gebrauchsanleitung	DE	CZ	Uživatelská příručka
Mode d'emploi	FR	DK	Brugervejledning
Gebruikershandleiding	NL	FI	Käyttöohjeet
User guide	GB	GR	Οδηγός χρήστη
Guía del usuario	ES	NO	Brukerveiledning
Manuale di istruzioni	IT	PL	Instrukcja obsługi
Bruksanvisning	SE		



Mercedes Vito / Viano 08/2005-



- |                                     |                               |
|-------------------------------------|-------------------------------|
| (DE) Anschluss Steckdose            | (CZ) Objímkový konektor       |
| (FR) Connection de la prise         | (DK) Stikdåse forbindelse     |
| (NL) Contactdoos aansluiting        | (FI) Pistorasia liitäntä      |
| (GB) Socket connection              | (GR) Υποδοχή σύνδεσης         |
| (ES) Conexión de la caja de enchufe | (NO) Tilkobling koblingsboks  |
| (IT) Allaccio zoccolo               | (PL) Połączenie przez gniazdo |
| (SE) Anslutning kontaktdosa         |                               |

DIN/ISO 1724			 1-7				
	1/L	2	3/31	4/R	5/58-R	6/54	7/58-L
Pmax	21W	2x21W		21W	52W	3x21W	52W
(DE)	Gelb	Blau	Weiß	Grün	Braun	Rot	Schwarz
(FR)	Jaune	Bleu	Blanc	Vert	Marron	Rouge	Noir
(NL)	Geel	Blauw	Wit	Groen	Bruin	Rood	Zwart
(GB)	Yellow	Blue	White	Green	Brown	Red	Black
(ES)	Amarillo	Azul	Blanco	Verde	Marrón	Rojo	Negro
(IT)	Giallo	Blu	Bianco	Verde	Marrone	Rosso	Nero
(SE)	Gul	Blå	Vit	Grön	Brun	Röd	Svart
(CZ)	Žlutá	Modrá	Bílá	Zelená	Hnědá	Červená	Černá
(DK)	Gul	Blå	Hvid	Grøn	Brun	Rød	Sort
(FI)	Keltainen	Sininen	Valkoinen	Vihreä	Ruskea	Punainen	Musta
(GR)	Κίτρινο	Μπλε	Λευκό	Πράσινο	Καφέ	Κόκκινο	Μαύρο
(NO)	Gul	Blå	Hvit	Grønn	Brun	Rød	Svart
(PL)	Żółty	Niebieski	Biały	Zielony	Brazowy	Czerwony	Czarny

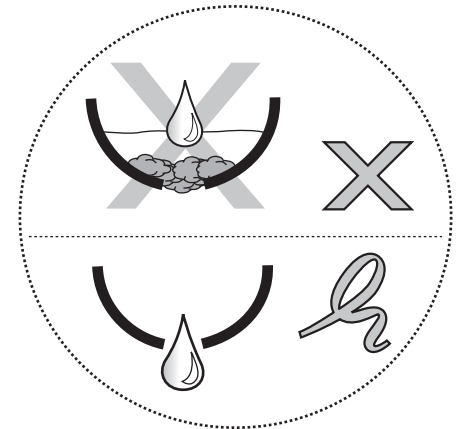
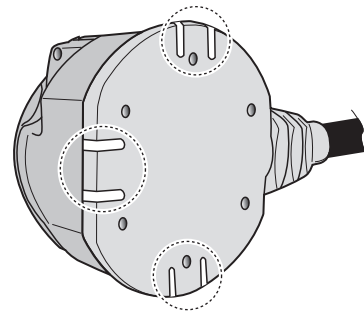
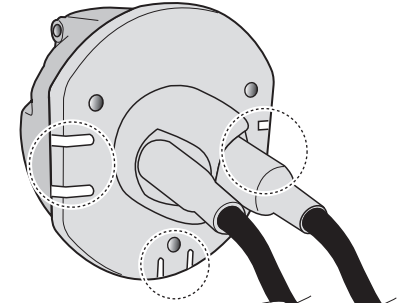
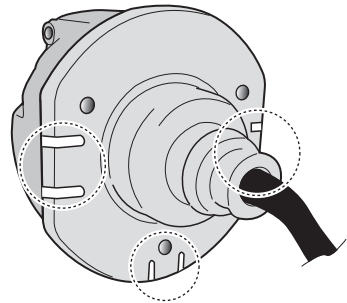
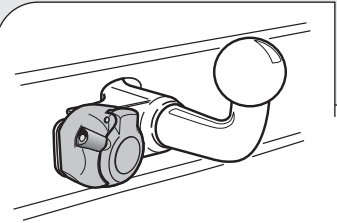

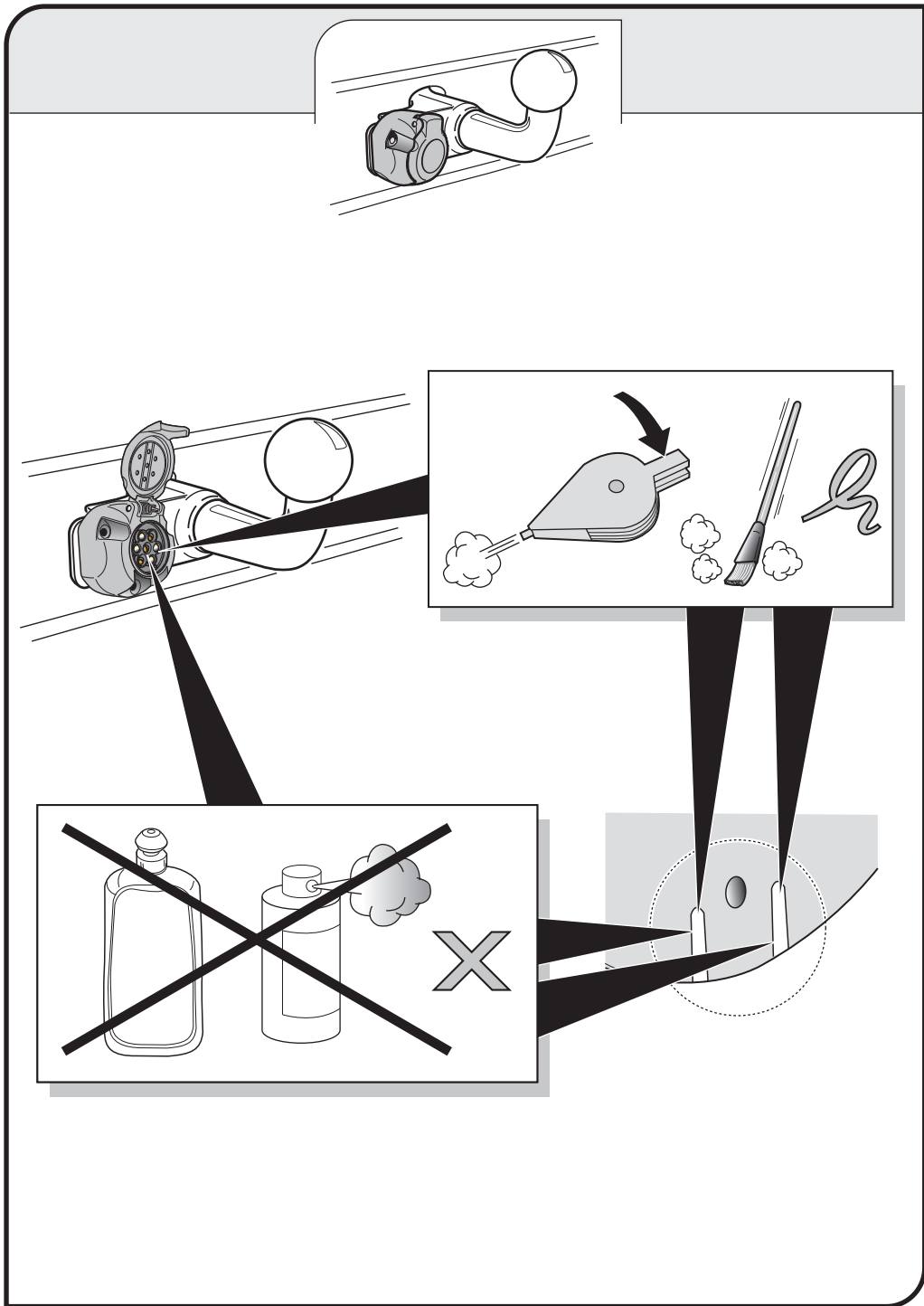

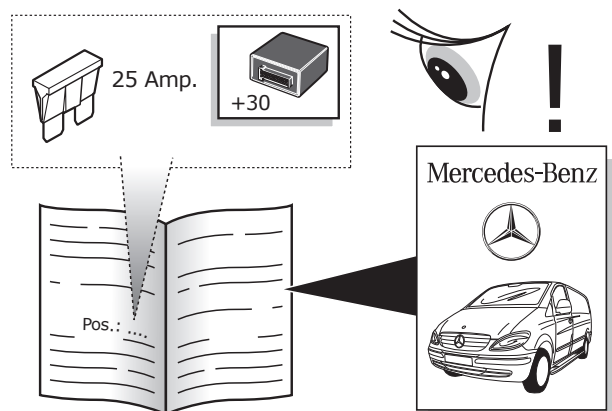

- (DE) Falls zutreffend soll bei einem angekoppelten Anhänger mit einer Nebelleuchte in Betrieb die Nebelleuchte des Fahrzeugs ausgeschaltet werden.
- (FR) Le cas échéant, lorsqu'une remorque, avec des anti-brouillard actifs, est branchée, les anti-brouillards du véhicule seront déconnectés.
- (NL) Indien van toepassing zal bij een gekoppelde aanhanger met een werkende mistlamp de mistlamp van het voertuig worden uitgeschakeld.
- (GB) In a coupled trailer with working fog lamp, the fog lamp of the vehicle will be switched off, if applicable.
- (ES) En un remolque acoplado con faros antiniebla en funcionamiento, se apagarán, si es aplicable, los faros antiniebla del vehículo.
- (IT) Se applicabile, in presenza di un rimorchio agganciato con una luce antinebbia in funzione, l'antinebbia del veicolo viene disinserito.
- (SE) Om tillämpligt kopplas ett fungerande dimljus bort från det anslutna släpet.
- (CZ) Pokud je na připojeném přívěsu zapnuta mlhovka, bude tato mlhovka na přívěsu vypnuta.
- (DK) Hvis det er relevant, vil på en tilkøbt anhænger med en fungerende tågelygte vognens tågelygte frakobles.
- (FI) Jos liitetyssä perävaunussa on toimiva sumuvalo, ajoneuvon sumuvalo kytketään pois päältä.
- (GR) Σε συζευγμένο ρυμουλκό στο οποίο λειτουργεί φανός ομίχλης, ο φανός ομίχλης του οχήματος θα απενεργοποιηθεί, εφόσον ενδείκνυται.
- (NO) Om nødvendig skal kjøretøyets tåkelys slås av, dersom tilhengeren som kobles til selv har et fungerende tåkelys.
- (PL) W stosownych przypadkach, przy przyłączonej przyczepie z działającymi światłami przeciwmgielnymi, zostaną wyłączone światła przeciwmgielne pojazdu.

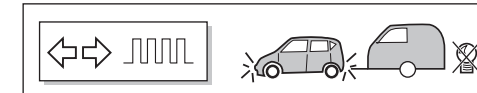
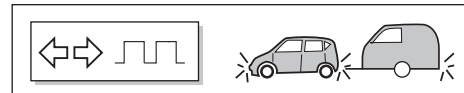
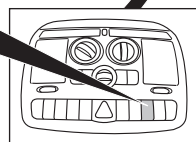
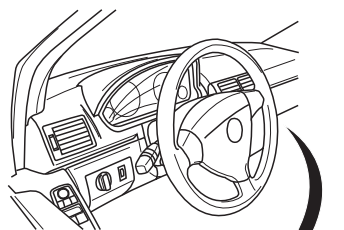
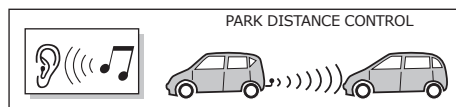

- (DU) Ein defektes Blinklicht an der Anhänger wird durch ein schnelleres Blinken der anderen Blinklichter angezeigt.
- (FR) Un clignotant défectueux de la remorque est signalé par le clignotement plus rapide des autres lampes clignotantes.
- (NL) Een defect knipperlicht van de aanhanger wordt aangegeven door het versneld knipperen van de overige knipperlichten.
- (GB) A defective indicator of the trailer is stated by a quicker flashing of the other indicator lights.
- (ES) Una luz de destellos defectuosa en vehículos con o sin remolque se indica mediante el parpadeo rápido de las restantes luces de destellos.
- (IT) Un indicatore di direzione difettoso del rimorchio viene indicato dal lampeggiare più rapido degli altri indicatori di direzione.
- (SE) En trasig blinkerlampa anges genom att de övriga blinkljusen blinkar snabbt.
- (CZ) Vadné směrové světlo přívěs je signalizováno rychlejším blikáním dalšího směrového světla.
- (DK) Hvis der findes et defekt indikatorlys i anhængerens vises det ved at det andet indikatorlys blinker hurtigere.
- (FI) Viallisesta vilkkulampusta ilmaistaan siten, että muut vilkkuvalot vilkkuvat nopeammin.
- (GR) Ο ελαττωματικός λαμπτήρας των φλας του αυτοκινήτου ή/και του ρυμουλκού υποδηλώνεται από ένα πιο γρήγορο αναβόσβημα του άλλου λαμπτήρα των φλας.
- (NO) Et defekt blinklys vises ved at de øvrige blinklysene blinker raskt.
- (PL) Uszkodzone światło wskaźnika w przyczepa jest sygnalizowane przez szybsze pulsowanie drugiego wskaźnika.